

Accessory
TRAILER HITCH

Application
2018 ODYSSEY

Publications No. <b>VERSION 1</b>
Issue Date <b>MAY 2017</b>

## PARTS LIST

### Trailer Hitch Kit P/N 08L92-THR-100

Trailer hitch



Ball mount



Hitch pin



Hitch pin clip



Receiver cover



6 Hex bolts



6 Plain washers



2 Clips



Bumper edge trim



Caution label  
(May not be used)



### Lower Antenna Kit (With Hands-Free ECU) P/N 08L91-THR-100A

**NOTE:** This accessory cannot be installed with accessory Backup Sensors.  
Hands-Free Access ECU

Hands-Free Access lower antenna



Wire tie



Accessory User's Information Manual



## TOOLS AND SUPPLIES REQUIRED

- Phillips screwdriver
- Flat-tip screwdriver
- Eye protection (face shield, safety goggles, etc.)
- Isopropyl alcohol
- Shop towel
- File
- Hex wrench
- Masking tape
- 10 mm Open end wrench
- Ratchet
- Torque wrench
- 6 mm and 12 mm Sockets
- Pushpin
- Drill
- 3 mm, 6 mm, 8 mm, and 10 mm Drill bits
- T-10 TORX bit
- Soap
- Blanket

*The following tools are available through the Honda Tool and Equipment Program. On the iN, click on Service > Service Bay > Tool and Equipment Program, then enter the number under "Search." Or, call 888-424-6857.*

- Trim Tool Set (T/N SOJATP2014)
- Plastic Trim Tool (T/N SILTRIMTL10)
- Air Saw (T/N AT192A)

## Illustration of the Trailer Hitch Installed on the Vehicle



TRAILER HITCH

QF52920AT

## INSTALLATION

**Customer Information:** The information in this installation instruction is intended for use only by skilled technicians who have the proper tools, equipment, and training to correctly and safely add equipment to your vehicle. These procedures should not be attempted by "do-it-yourselfers."

1. Disconnect the negative cable from the battery:
  - Wrap a shop towel around the hood latch.

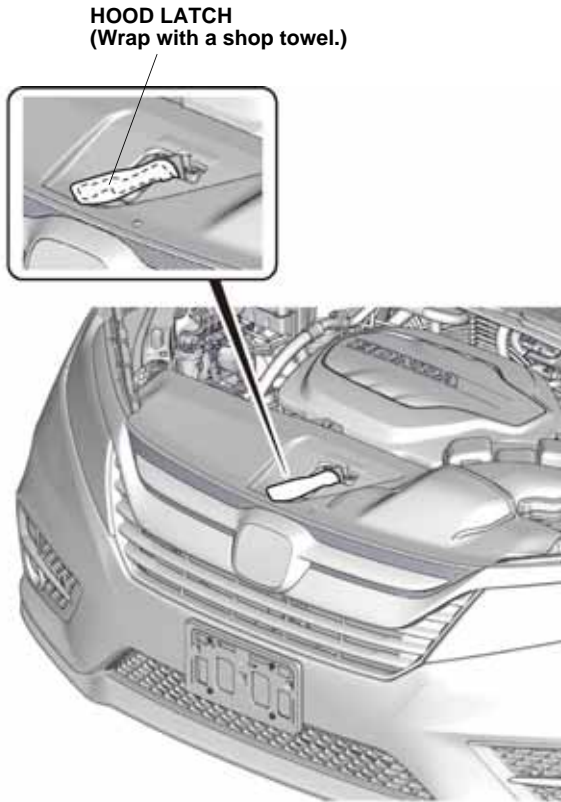

QF52702AG

- Remove the front bulkhead cover.

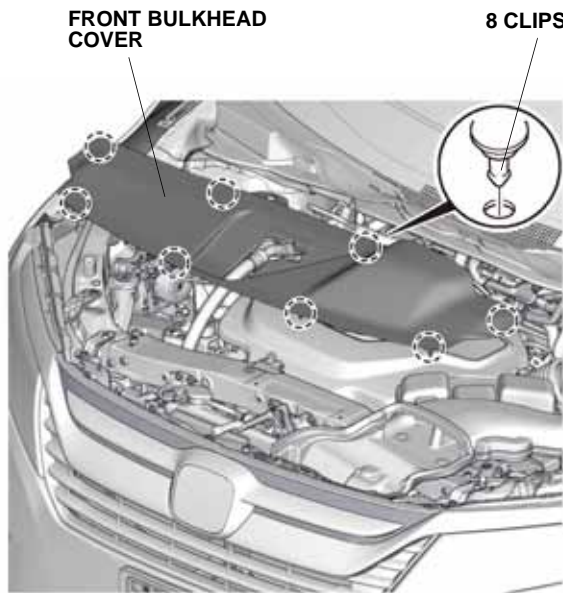

QF52703AG

- Remove the intake air tube.
- Disconnect the negative cable from the battery.

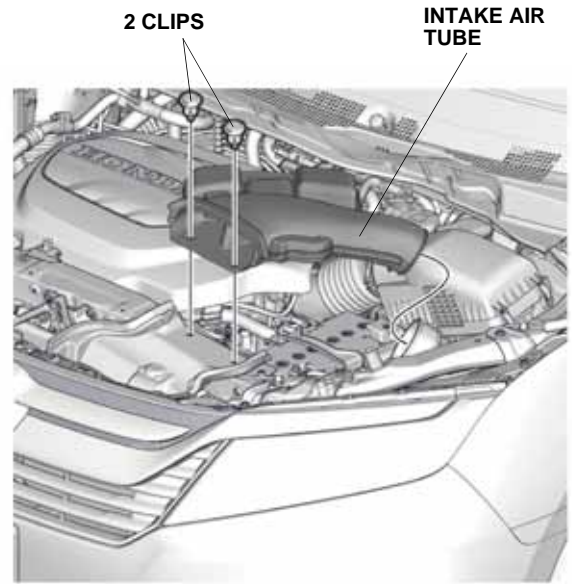

QF52704AG

2. Remove the rear bumper:
  - Apply masking tape as shown.

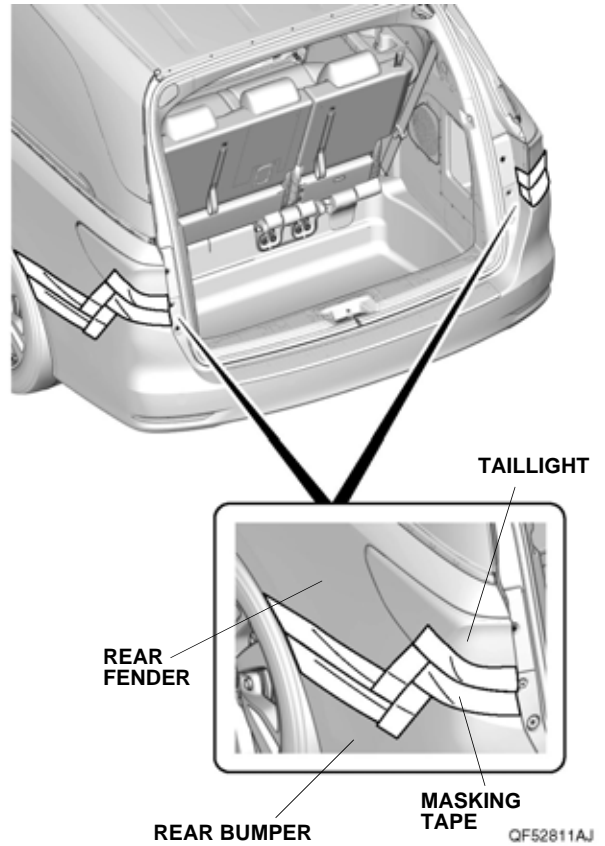

QF52811AJ

- Remove six self-tapping screws, two clips, two large hex bolts, and two small hex bolts as shown.

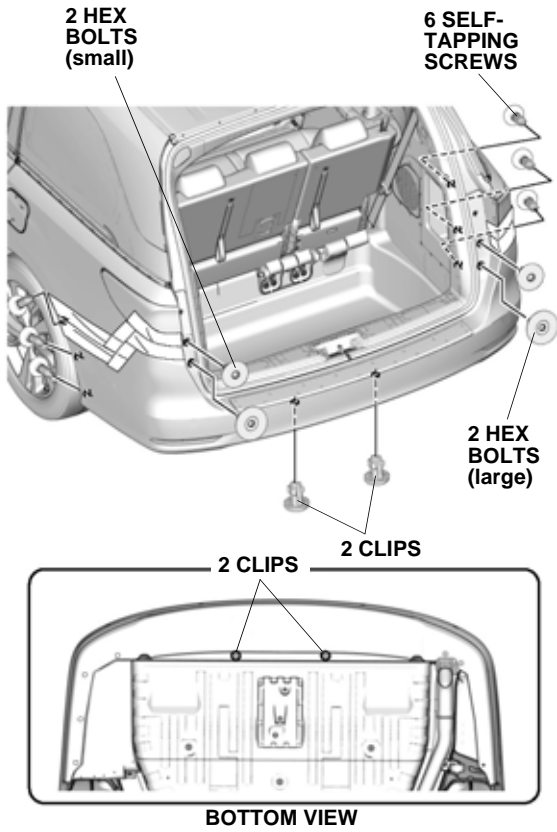

QF52930AT

- Remove the self-tapping screw and one bolt.

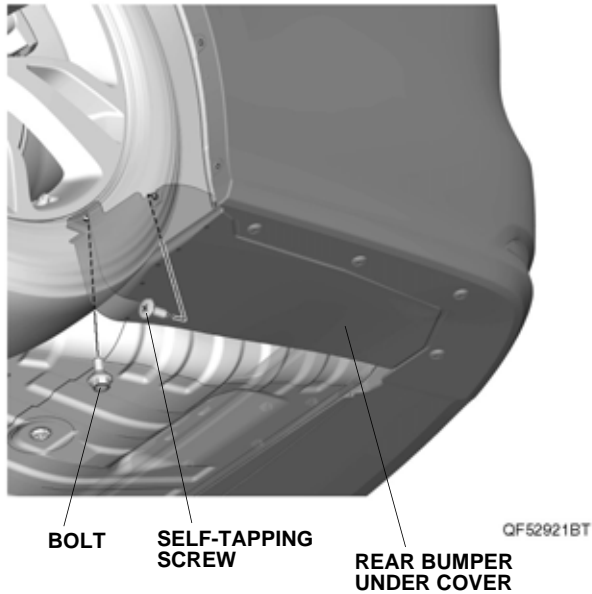

- With the help of an assistant, release nine retaining tabs on each side.

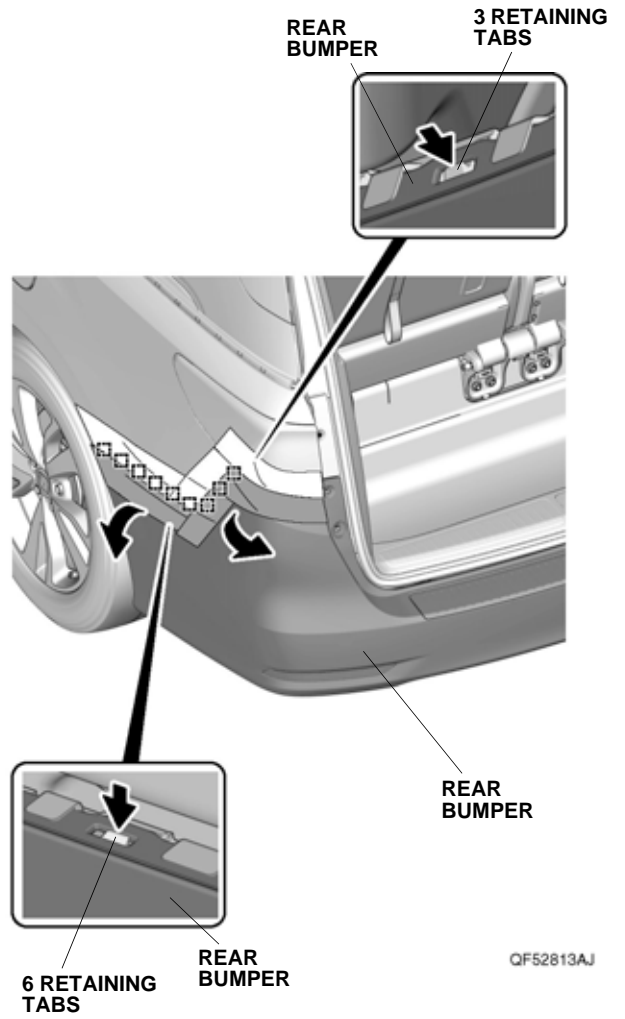

QF52813AJ

- With the help of an assistant, remove the rear bumper and unplug the vehicle connectors (if equipped).
- Place the rear bumper on a blanket.

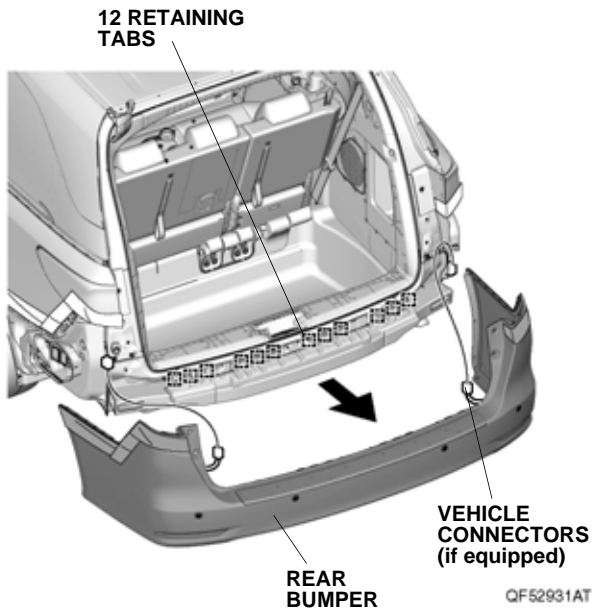

3. Using soap and water, lubricate the rubber mount and remove the muffler from the rubber mount. **NOTE:** Be careful not to damage the muffler.

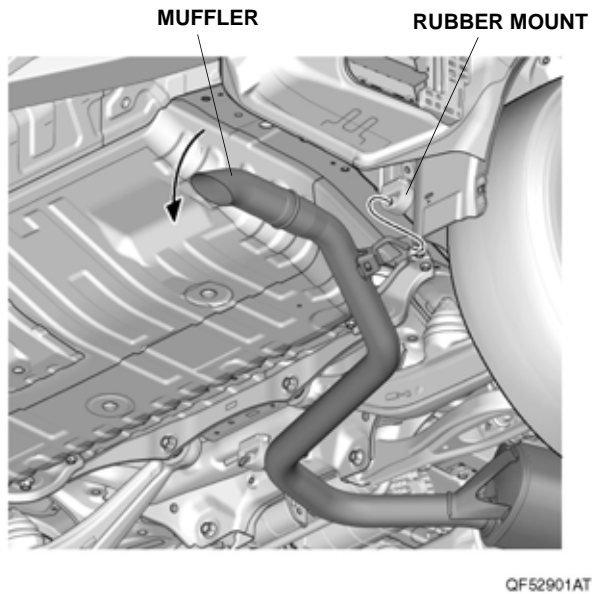

4. Install the trailer hitch to the vehicle frame with six plain washers and six hex bolts. First, torque the hex bolts to 32 N·m (24 lb·ft) in the order shown below. Then, torque the hex bolts to 64 N·m (47 lb·ft) in the order shown below. **NOTE:** Have an assistant help you when installing the trailer hitch.

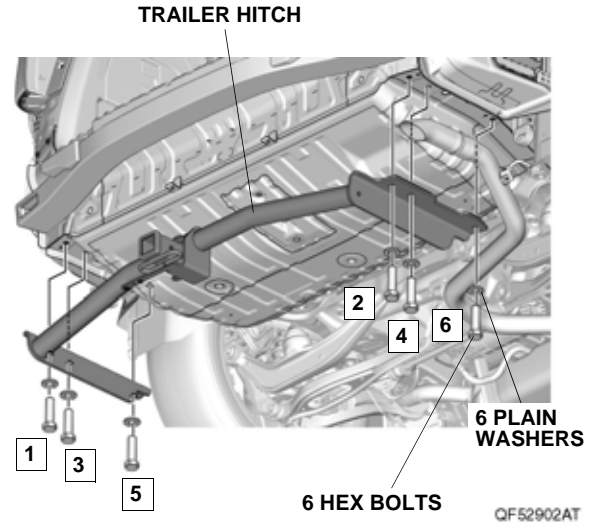

5. Install the muffler.
6. Remove the rear bumper under cover.

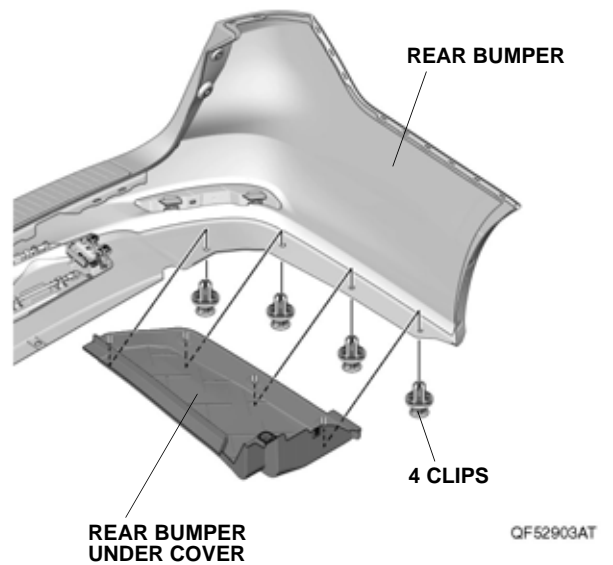

If the vehicle is equipped with Hands-Free Access, continue with step 7; otherwise, go to step 14.

### With Hands-Free Access

7. Unplug the vehicle 3-pin connector from the Hands-Free Access ECU.

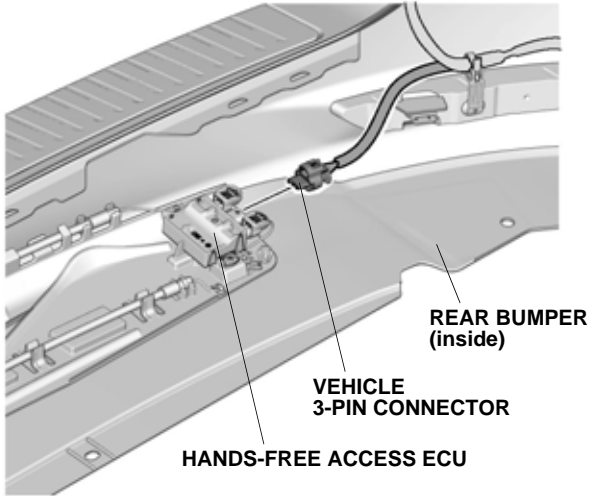

8. Remove the Hands-Free Access unit.

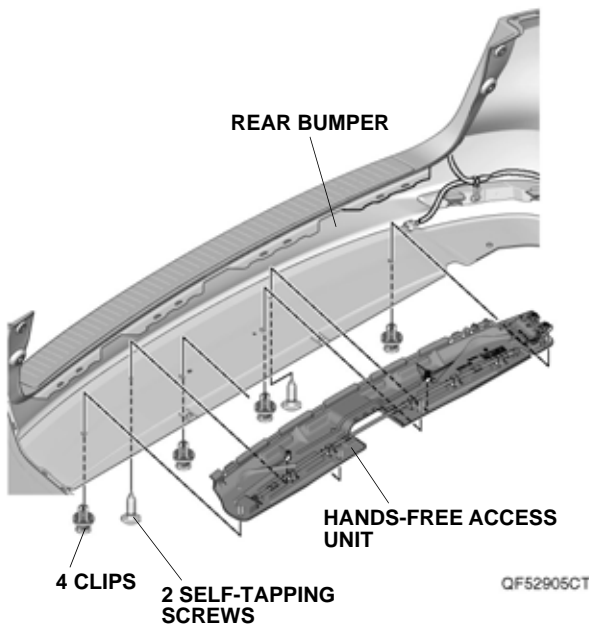

9. Cut the wire tie on the lower antenna.  
NOTE: Be careful not to damage the lower antenna.

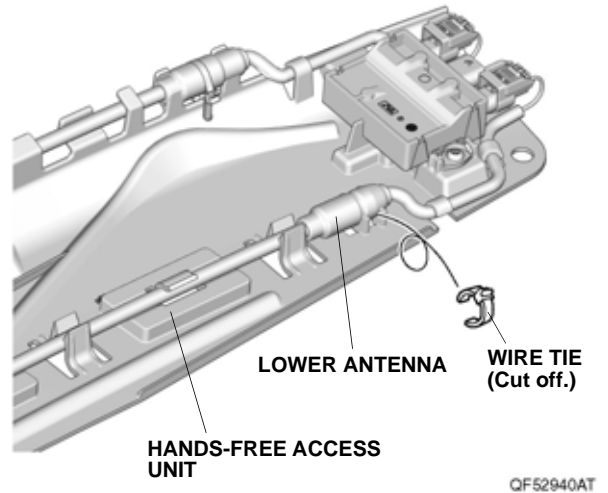

10. Remove the Hands-Free Access ECU and the lower antenna from the Hands-Free Access unit.

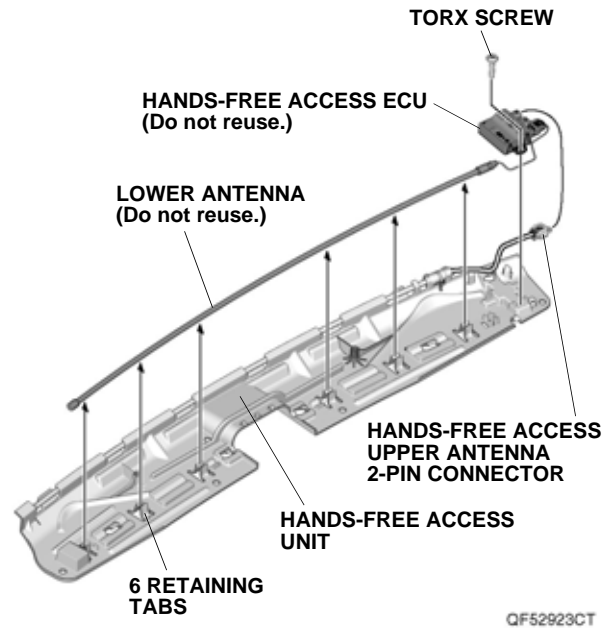

11. Install the new Hands-Free Access ECU on the Hands-Free Access unit with the TORX screw, and plug the Hands-Free Access upper antenna 2-pin connector into the new Hands-Free Access ECU.

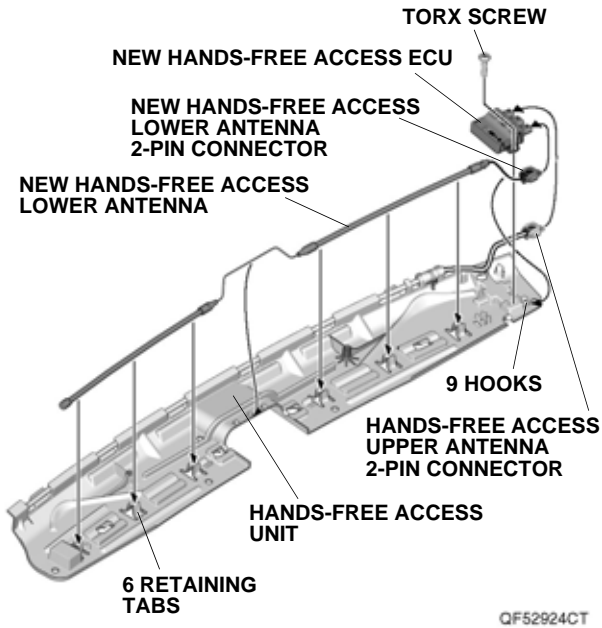

12. Install the new Hands-Free Access lower antenna on the Hands-Free Access unit, and plug the new Hands-Free Access lower antenna 2-pin connector into the new Hands-Free Access ECU.

13. Secure the new Hands-Free Access lower antenna to the Hands-Free Access unit with one wire tie. **NOTE:** Lower antenna and Hands-Free Access ECU must both be replaced for the system to function properly.

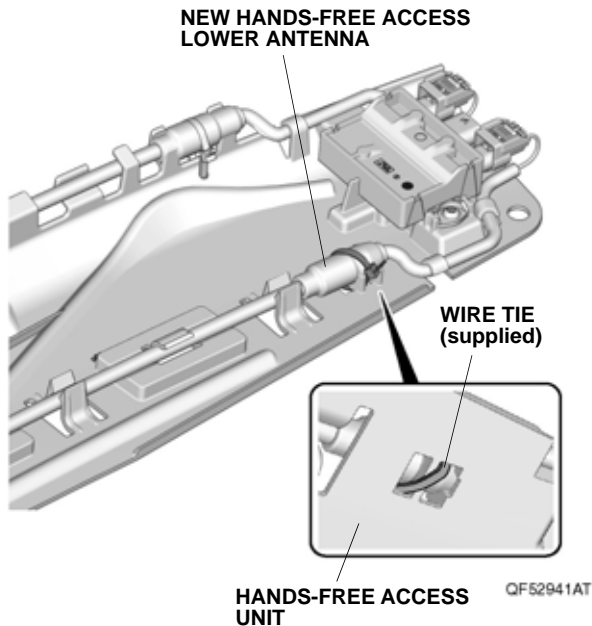

14. While wearing eye protection, use an air saw to cut the rear bumper under cover at the scribe mark. Remove any burrs.

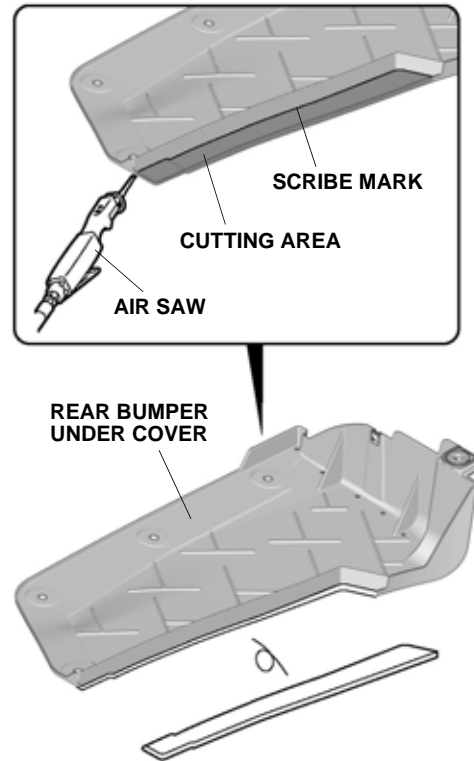

QF52922AT

15. Using a pushpin, pierce the two scribe marks on the rear bumper as shown.  
 NOTE: Make sure to pierce the scribe marks perpendicular to the rear bumper.

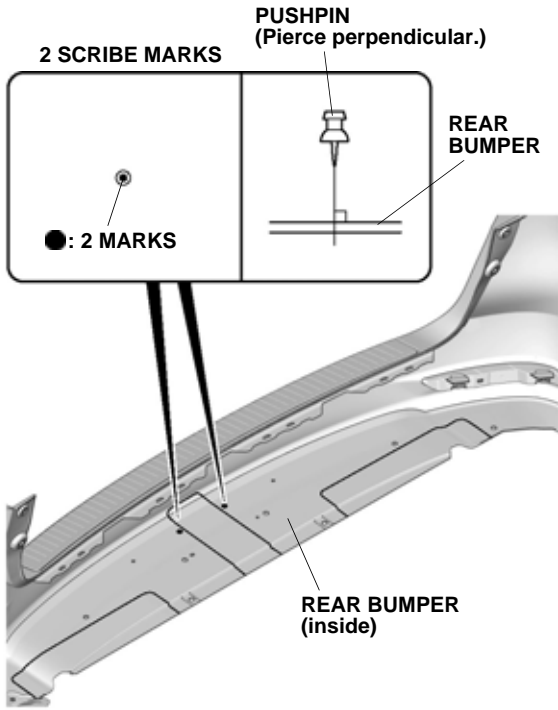

QF52907AT

16. While wearing eye protection, drill the two pierced marks with a 3 mm drill bit, with a 6 mm drill bit, with an 8 mm drill bit, then finish with a 10 mm drill bit.  
 NOTE: Make sure to drill perpendicular to the rear bumper. Remove any burrs.

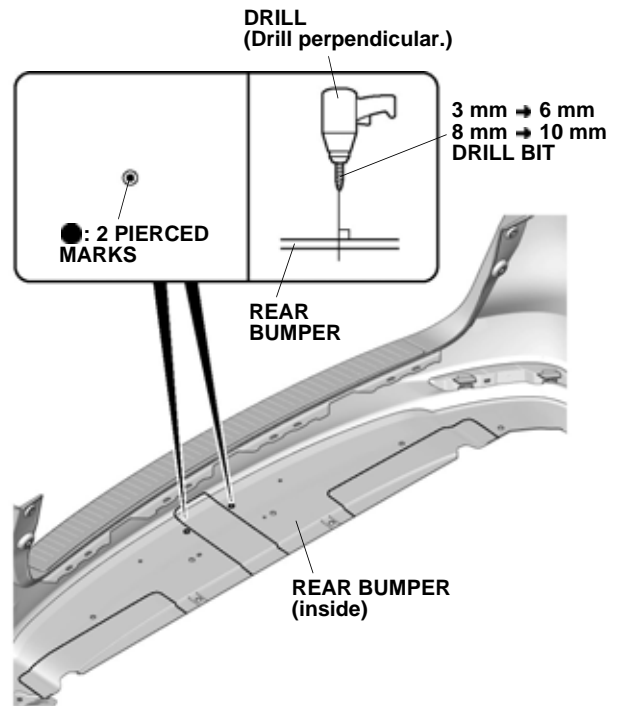

QF52908AT

17. Remove the exhaust cover.

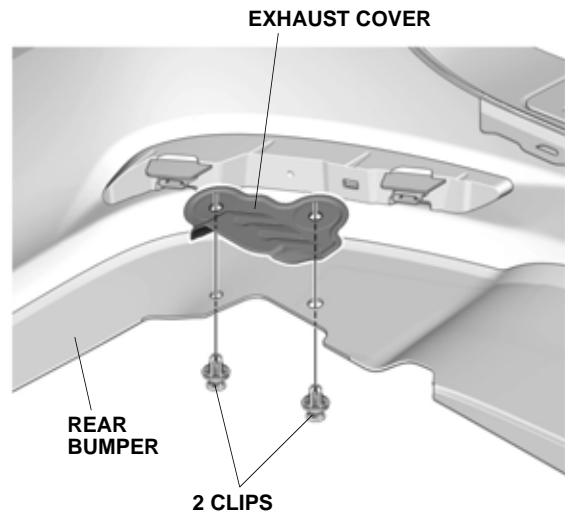

QF52925AT



18. While wearing eye protection, use an air saw to cut the rear bumper at the scribe marks. Remove any burrs.

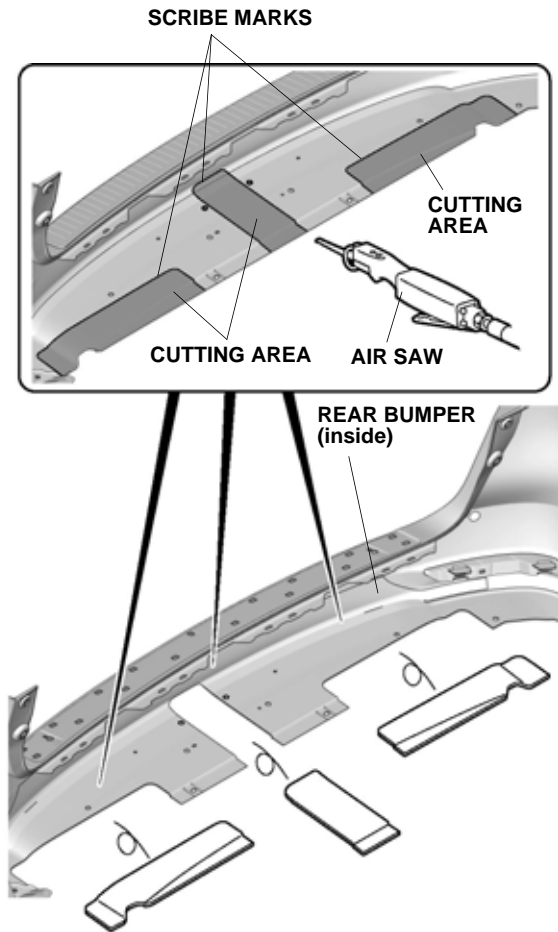

QF52909AT

If the vehicle is equipped with Hands-Free Access, continue with step 19; otherwise, go to step 20.

### With Hands-Free Access

19. Install the Hands-Free Access unit. Plug the vehicle 3-pin connector into the new Hands-Free Access ECU.

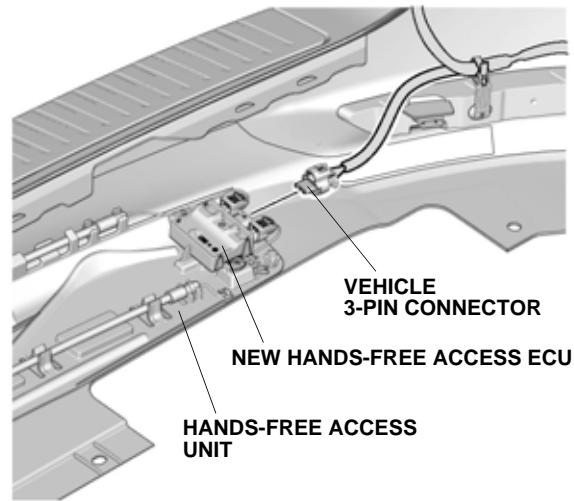

QF52932AT

20. Install the bumper edge trim to the rear bumper with the two clips.

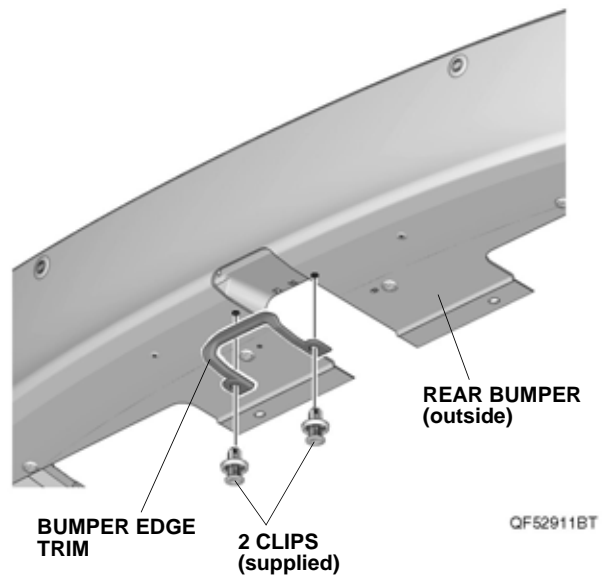

QF52911BT

21. Install the rear bumper under cover and exhaust cover on the rear bumper. Install the rear bumper.

**If the vehicle is equipped with a 10-speed transmission, continue with step 22; otherwise, go to step 24.**

22. Using isopropyl alcohol on a shop towel, thoroughly clean the trailer hitch where the caution label will attach.

NOTE: Vehicles with a 9-speed transmission have a tow rating of 3000 lbs max.

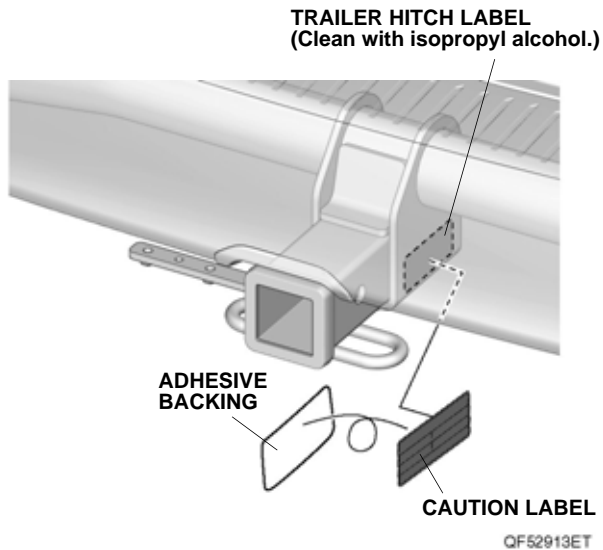

23. Remove the adhesive backing from the caution label, and attach the caution label to the trailer hitch label.
24. Check that all wire harnesses are routed properly and that all connectors are plugged in.
25. Connect the negative cable to the battery.
26. Install the front bulkhead cover and the intake air tube.
27. Press and hold the audio unit power button for 2 seconds to restore the audio and navi (if equipped) system functions.

28. Set the clock on vehicles without navigation.

**Give a copy of this page to your customer.**

Whenever you remove the hitch pin clip, the hitch pin, and the ball mount, store them securely in the cargo area. Install the receiver cover into the opening at the end of the trailer hitch. When you reinstall the ball mount, store the receiver cover in the cargo area.

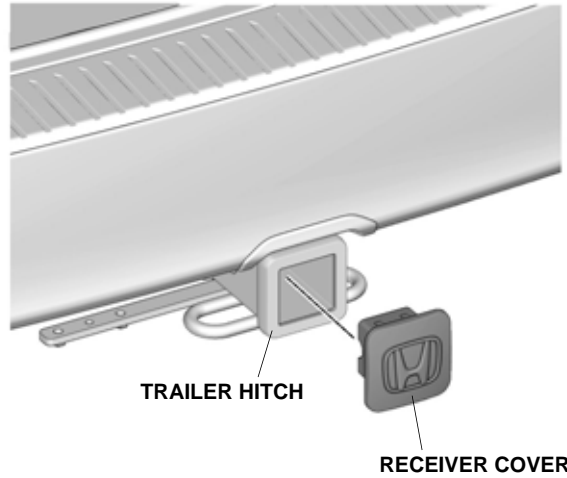

QF52915AT

Install the ball mount into the trailer hitch using a hitch pin clip and hitch pin.

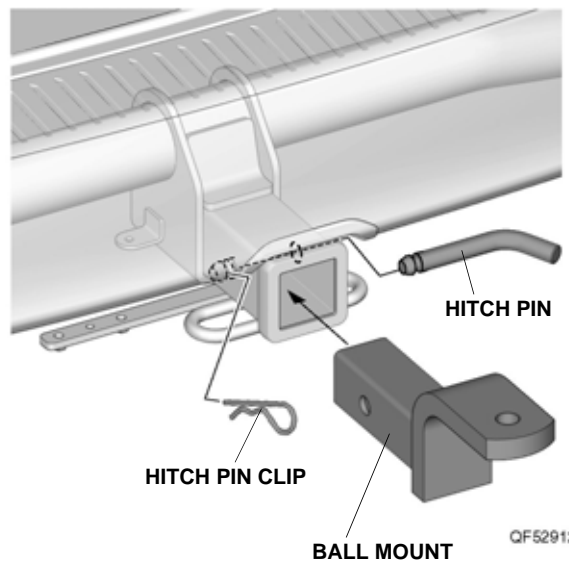

QF52912AT

After the first 600 miles (1,000 km) of towing, have your Honda Dealer re-check the tightness of the trailer hitch bolts.