

## PARTS LIST

**Heated Steering Wheel Kit  
P/N 08U97-THR-100A**

Steering wheel



Control unit



2 TORX screws, 4 x 14 mm



Cable reel



Cable reel cord



2 TORX bolts, 6 x 23 mm



Information manual



10A Fuse  
(May not be used)



Steering wheel bolt



**Switch Kit  
P/N 08U97-THR-100B  
P/N 08U97-THR-100C**

HSW switch



## TOOLS AND SUPPLIES REQUIRED

Phillips screwdriver  
10 mm Open end wrench  
10 mm Hex wrench  
Ratchet  
T-20 and T-30 TORX bits  
Torque wrench  
Steering wheel puller  
Shop towel  
Masking tape  
i-HDS/DST-i

*The following tools are available through the Honda Tool and Equipment Program. On the iN, click on Service > Service Bay > Tool and Equipment Program, then enter the number under "Search." Or, call 888-424-6857.*

- Trim Tool Set (T/N SOJATP2014)
- Plastic Trim Tool (T/N SILTRIMTL10)

### **Illustration of the Heated Steering Wheel in the Vehicle**

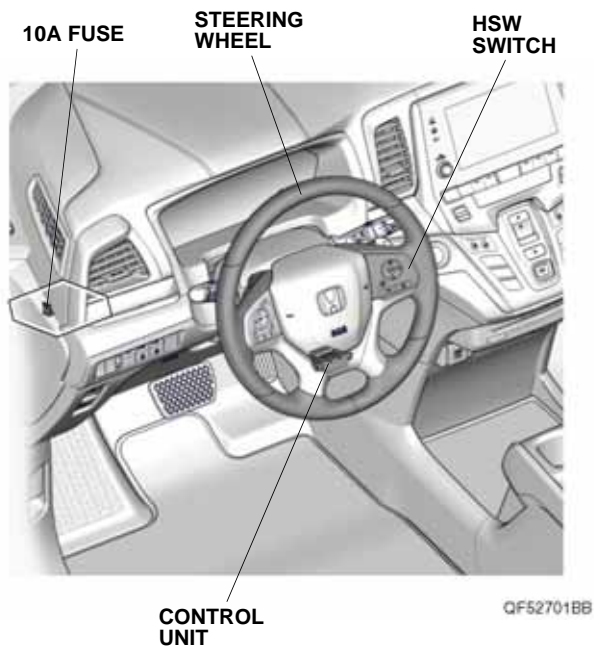

## INSTALLATION

**Customer Information:** The information in this installation instruction is intended for use only by skilled technicians who have the proper tools, equipment, and training to correctly and safely add equipment to your vehicle. These procedures should not be attempted by "do-it-yourselfers."

### NOTE:

- Observe all safety notes and precautions in the service information in addition to those in this Installation Instruction.
  - Be careful not to damage the vehicle.
  - After installing the steering wheel, you must align the steering wheel spoke angle to the straight ahead position by adjusting the front toe.
1. Turn the steering wheel so the front wheels are in the straight-ahead position.
    - Wrap a shop towel around the hood latch.
  2. Disconnect the negative cable from the battery:
    - Wrap a shop towel around the hood latch.

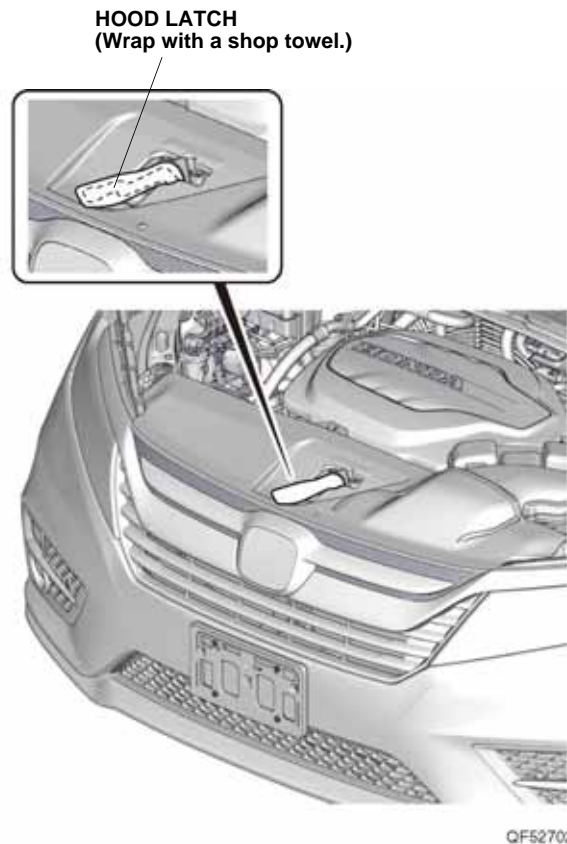

- Remove the front bulkhead cover.

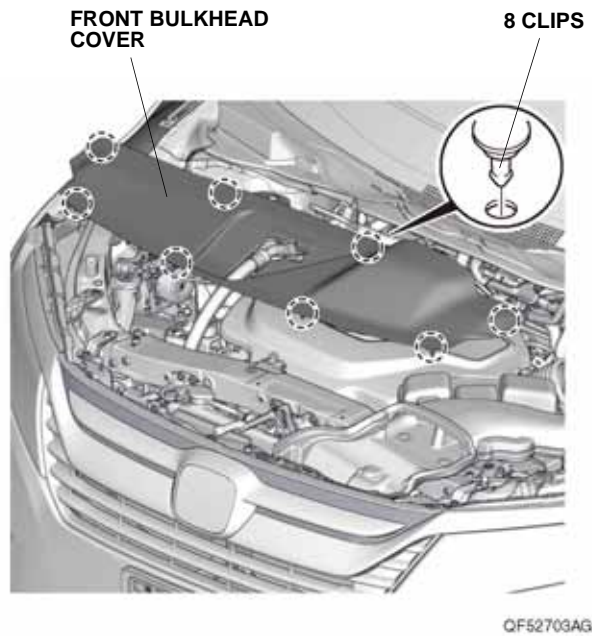

- Remove the intake air tube.
- Disconnect the negative cable from the battery, and wait at least 3 minutes before you start to install the steering wheel.

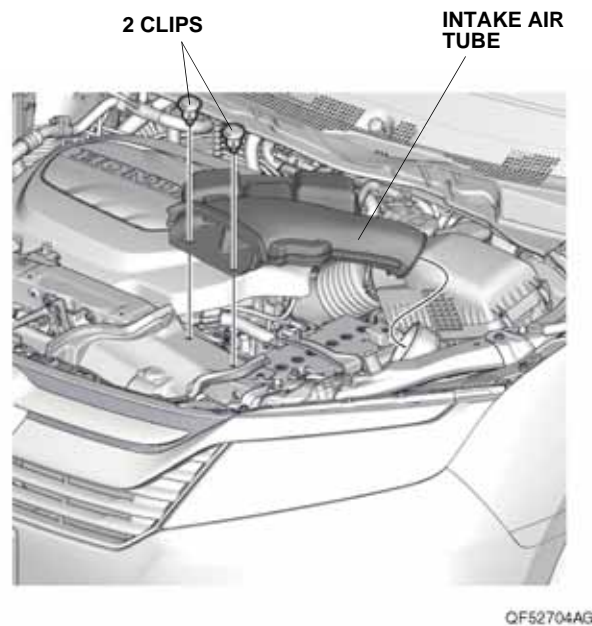

- Pull away the door opening seal, and remove the driver's dashboard side lid.

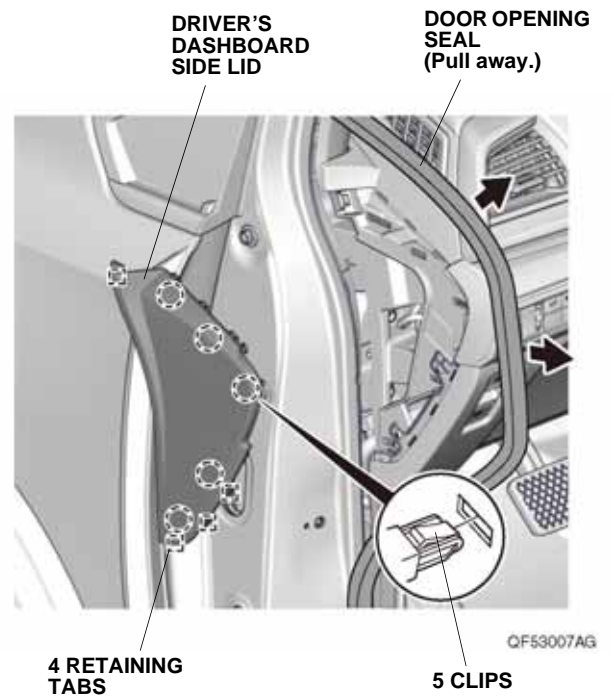

- Remove the driver's dashboard lower cover, and unplug the vehicle connectors.

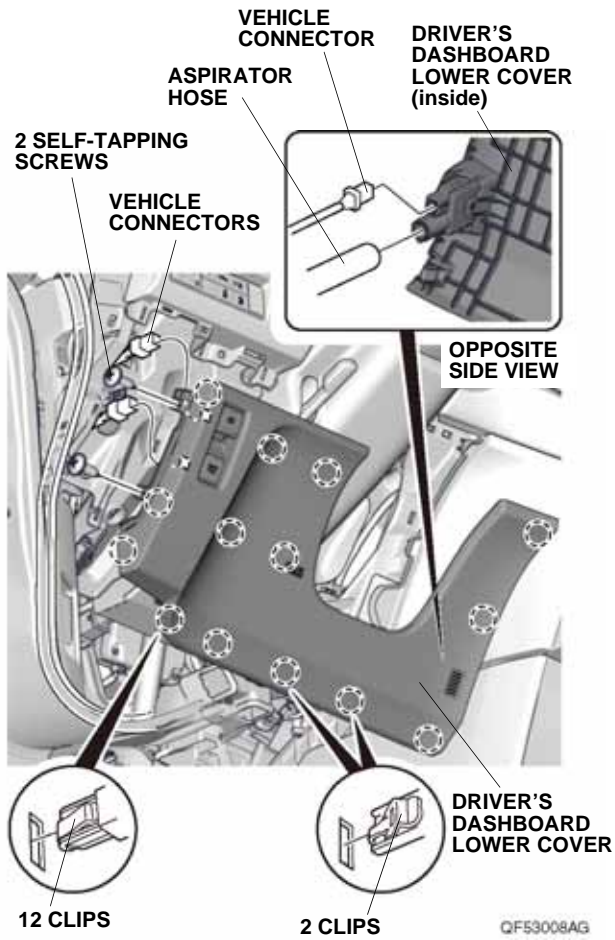

- Lower and pull out the steering wheel as shown, and remove two TORX bolts.

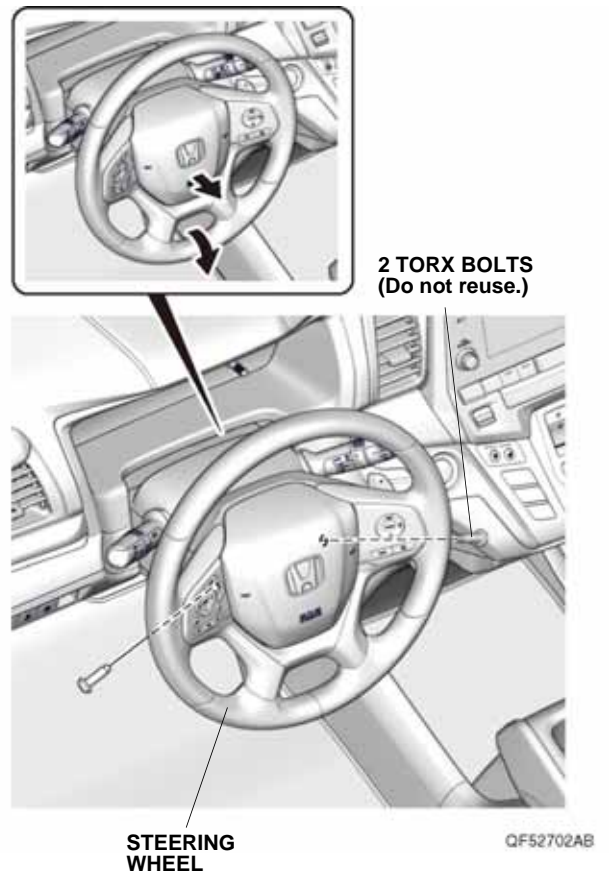

- Unplug the vehicle connectors.  
NOTE: Be careful not to damage the vehicle connectors.

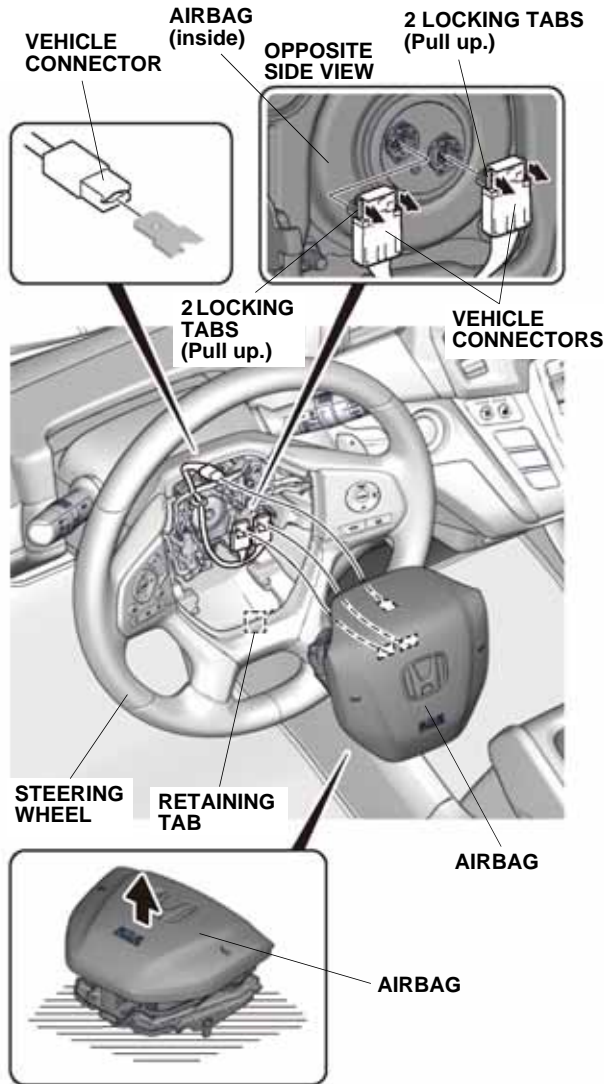

- Remove the airbag. Do not drop the removed airbag or hit it on an object. Place the removed airbag in a safe place with the pad surface (top) facing upward.

- With the front wheels aligned in the straight ahead position, unplug the vehicle connector from the cable reel, and loosen the steering wheel bolt.

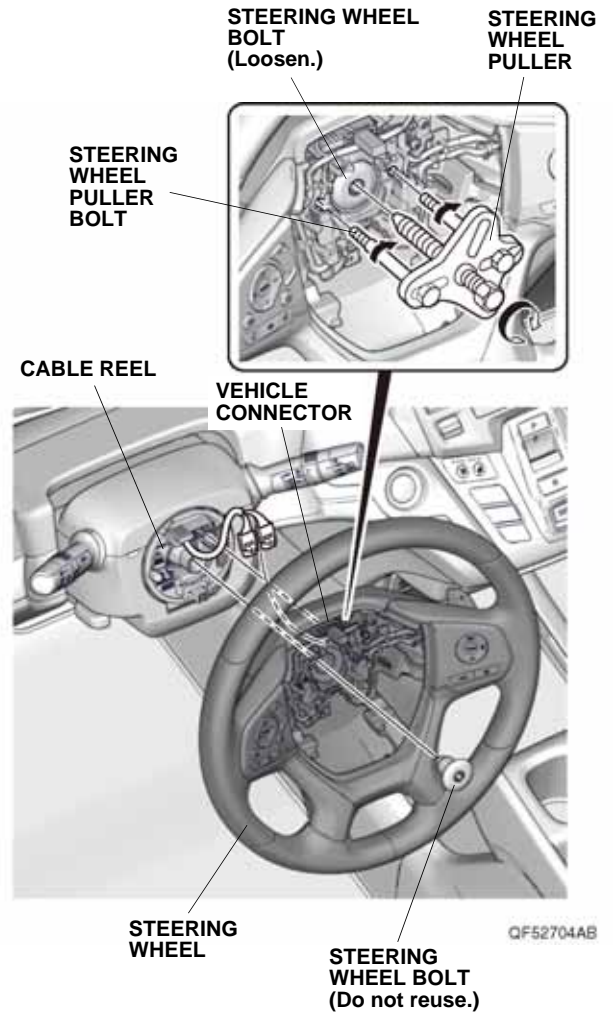

- Using a steering wheel puller, release the steering wheel. Do not thread the steering wheel puller bolts in more than 5 mm (0.20 in.). When removing the vehicle steering wheel, take care not to move the front wheels.
- Remove the steering wheel bolt, then remove the steering wheel.

- Apply masking tape to the upper column cover as shown.

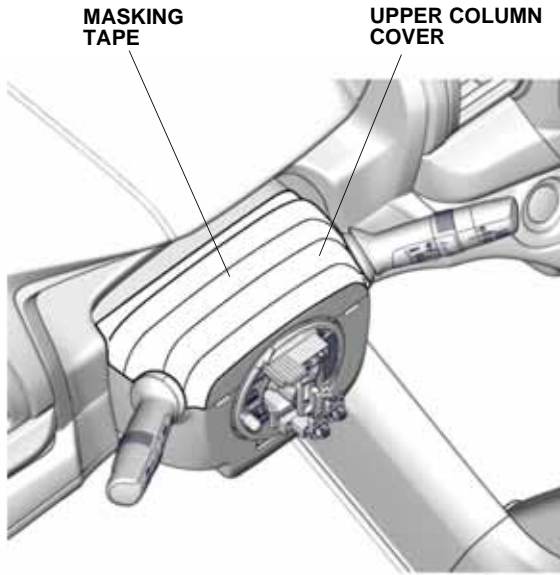

QF52705AB

- Using a plastic trim tool, release two retaining tabs.

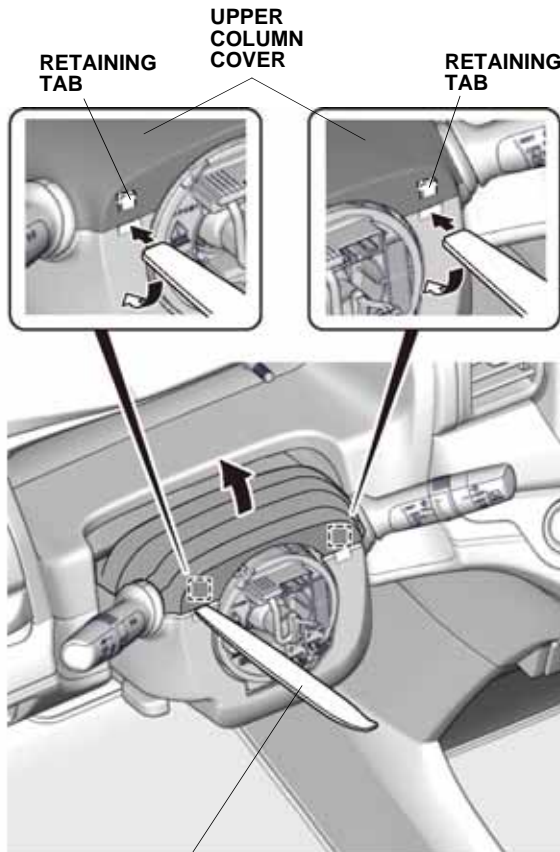

QF52706AB

- Release the upper column cover, and secure it to the dashboard with masking tape.

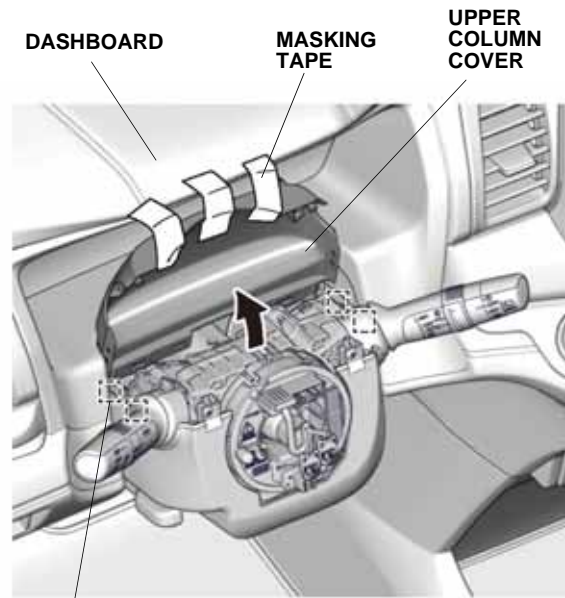

4 RETAINING TABS

QF52707AB

- Remove two self-tapping screws from the lower column cover.

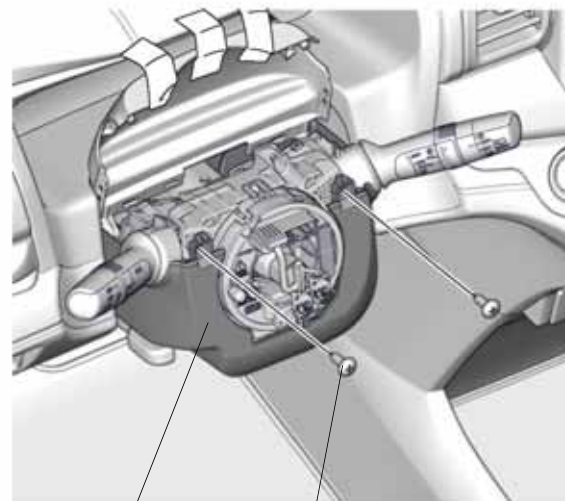

LOWER COLUMN COVER

2 SELF-TAPPING SCREWS

QF52708AB

15. Remove the lower column cover.

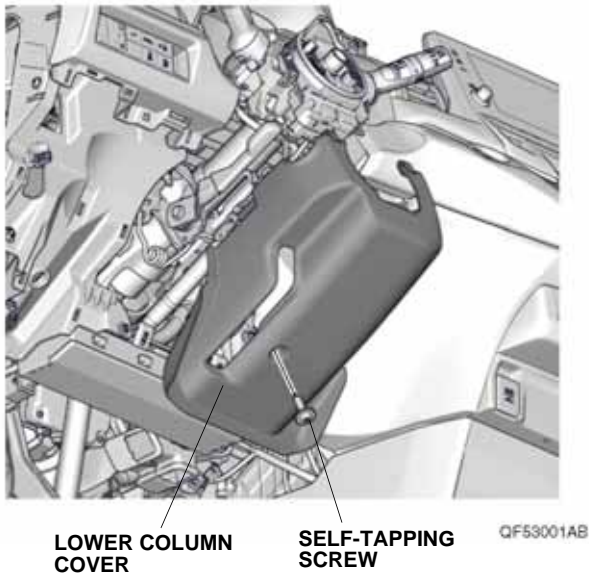

16. Unplug the vehicle connectors from the cable reel.

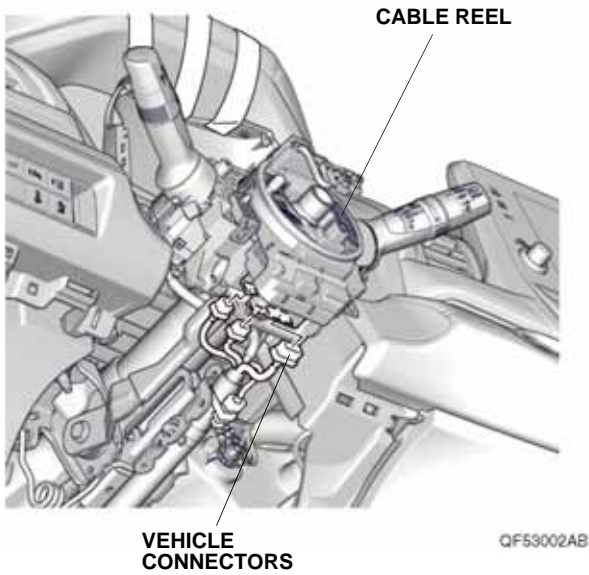

17. To prevent turning from the cable reel, apply masking tape to the cable reel. Remove the cable reel.

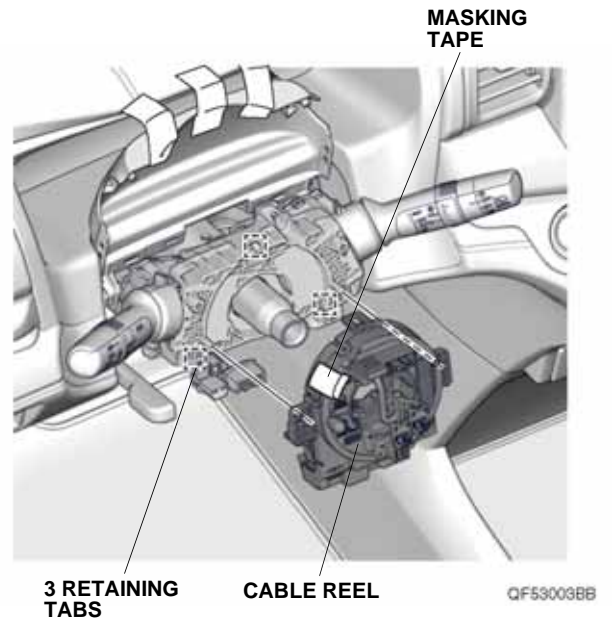

18. Remove the masking tape. Remove the steering angle sensor.  
 NOTE: Make sure the steering angle sensor alignment tab is in the six o'clock position before disassembling.

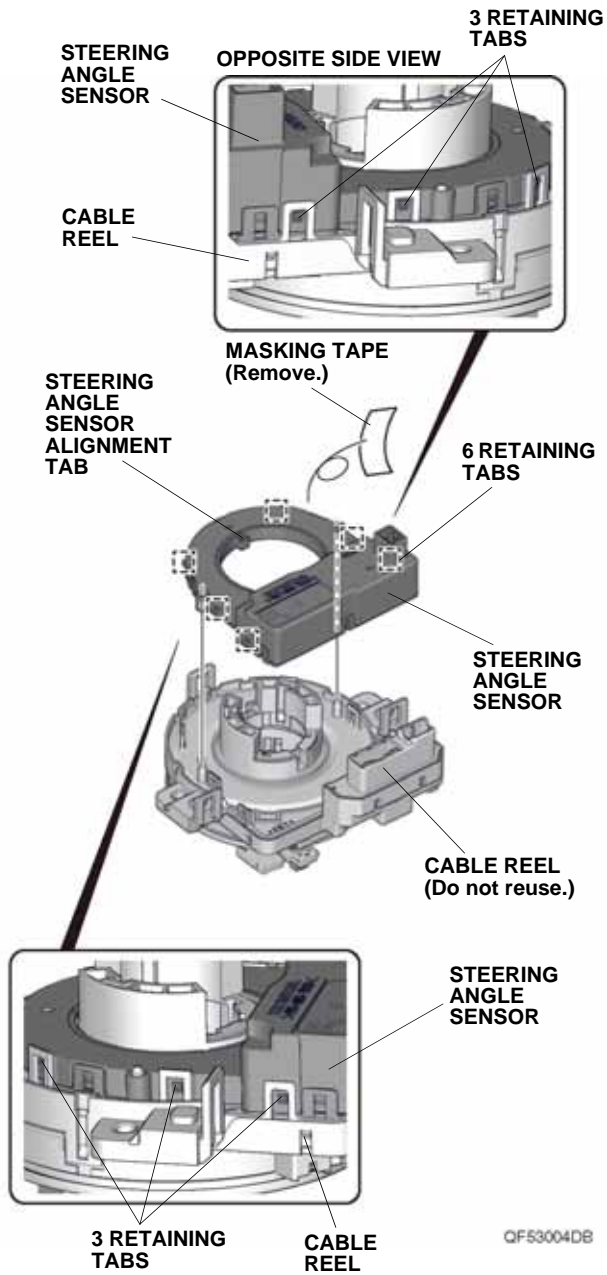

19. Install the steering angle sensor to the new cable reel with six retaining tabs.  
 NOTE: Make sure the steering angle sensor alignment tab remains in the six o'clock position at all times.

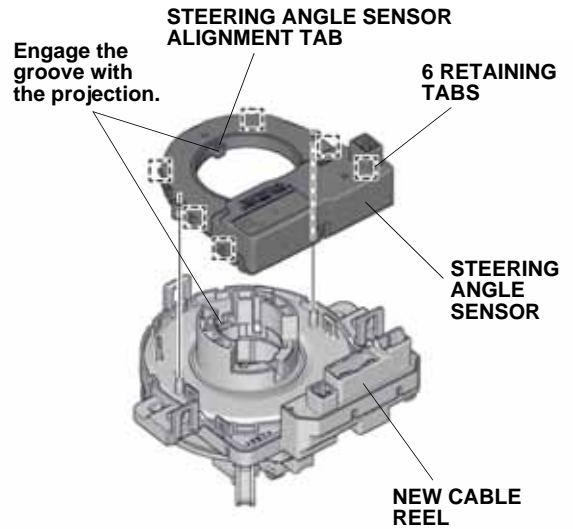

20. Remove the tape to free the vehicle 2-pin connector, and remove the dummy connector from the vehicle 2-pin connector.

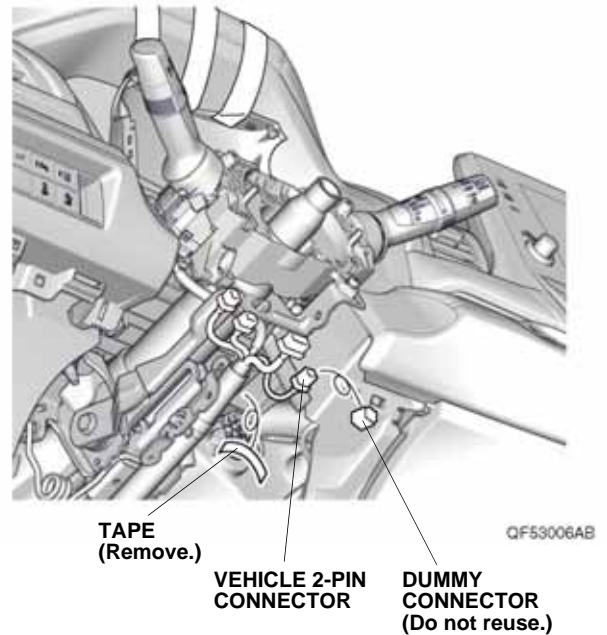



21. Install the new cable reel with three retaining tabs.

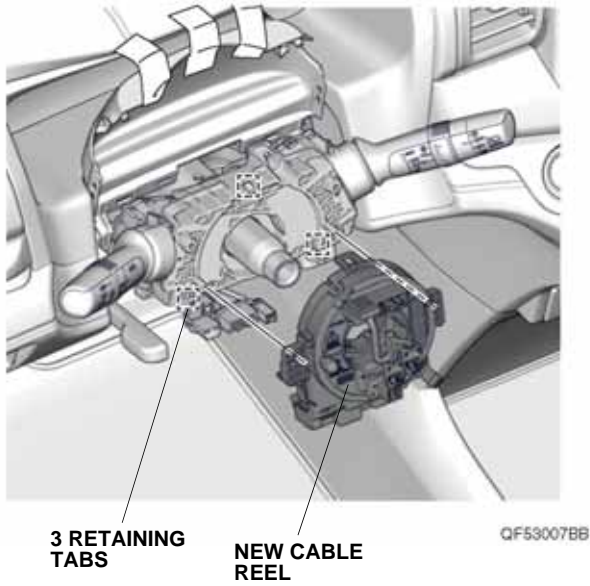

22. Plug the vehicle connectors into the new cable reel, and remove the locking pin.

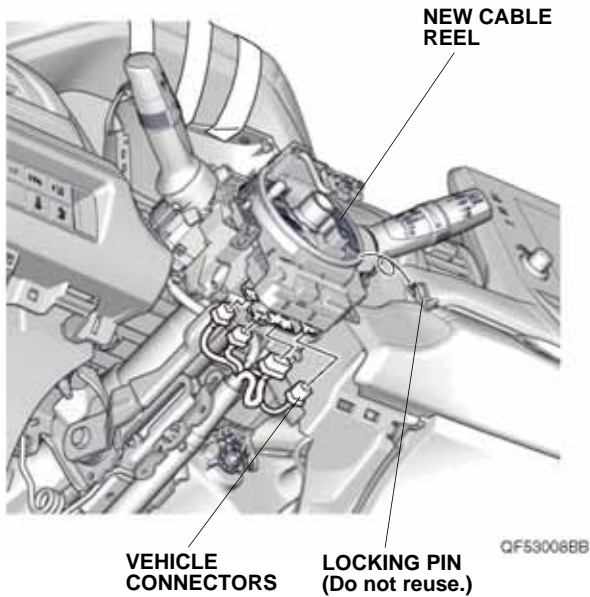

23. Remove the steering wheel cover.

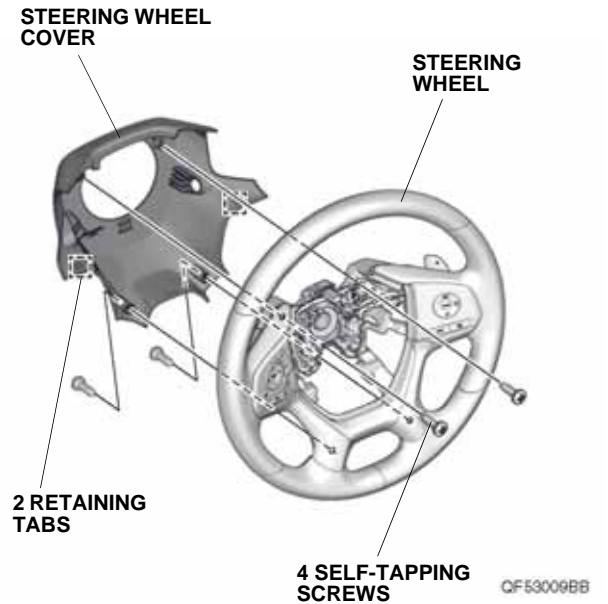

24. Remove the left and right paddle shifters and unplug the vehicle connectors.

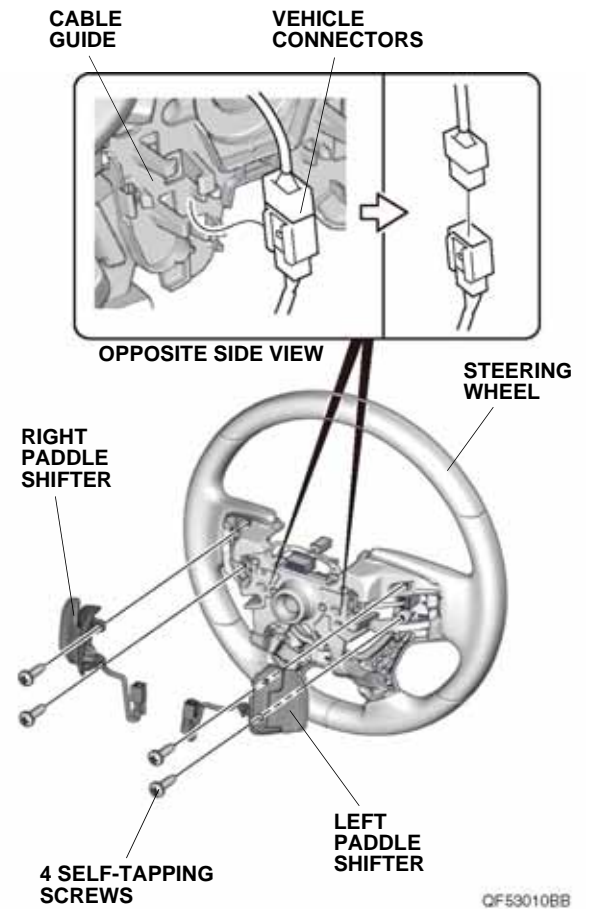

25. Remove the center spoke trim.

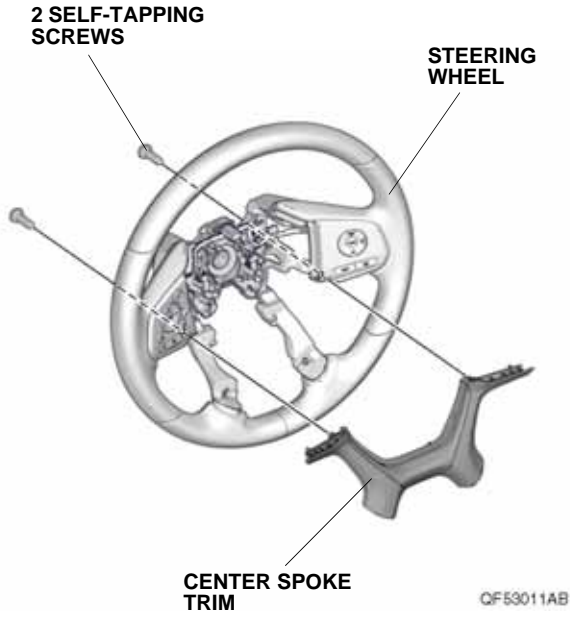

26. Remove the vehicle switches and unplug the vehicle connectors.

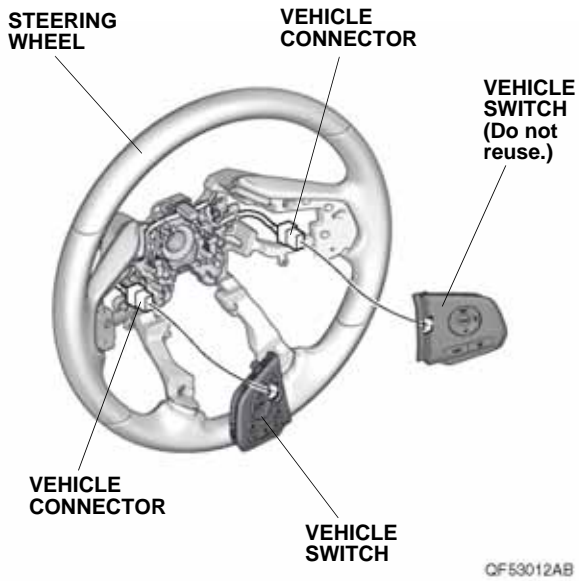

27. Remove the cable reel cord.

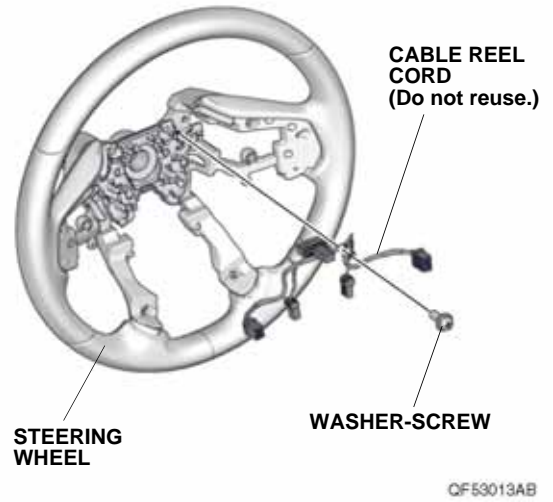

28. Remove the cable guide.

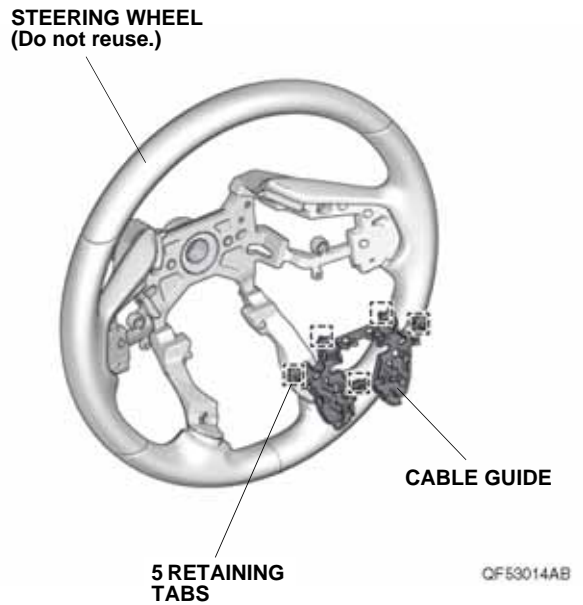

29. Install the cable guide on the new steering wheel with five retaining tabs.

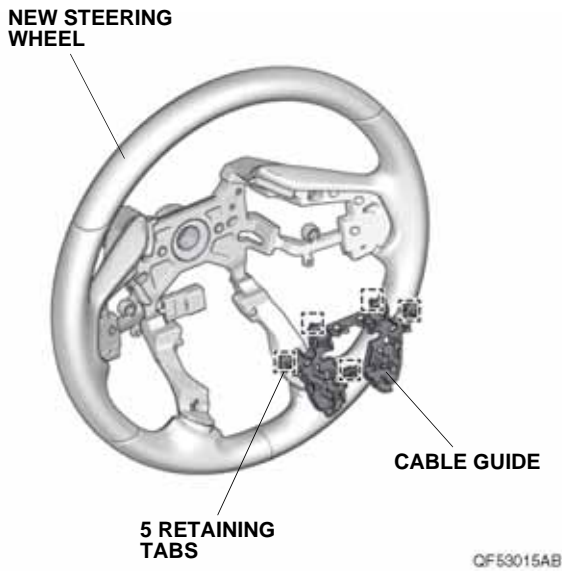

30. Install the new cable reel cord to the cable guide with one washer-screw removed in step 27. Plug the new cable reel cord 4-pin connector into the new steering wheel 4-pin connector, and secure the new cable reel cord to the cable guide.

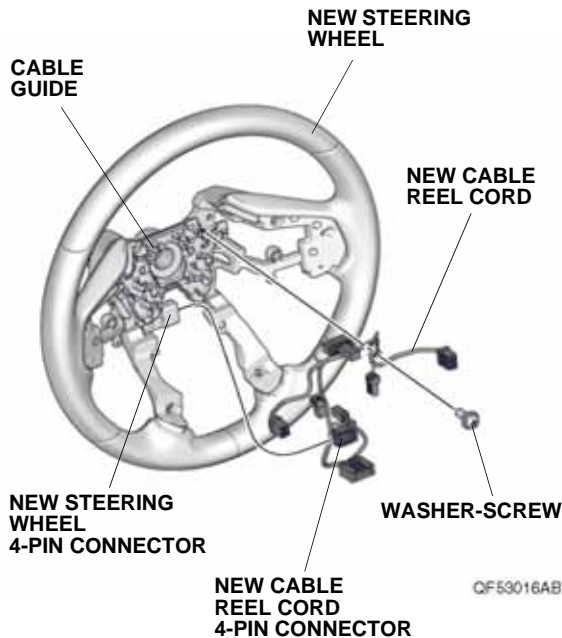

31. Plug the new cable reel cord 12-pin connector into the HSW switch, and install the HSW switch on the new steering wheel. Plug the new cable reel cord 10-pin connector into the vehicle switch, and install the vehicle switch on the new steering wheel.

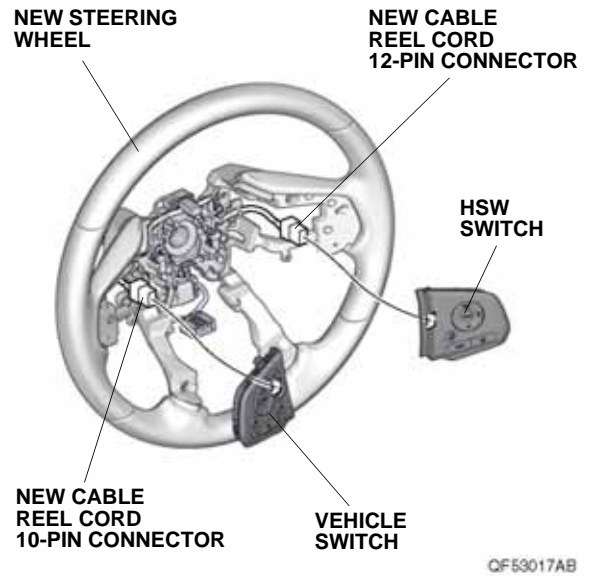

32. Install the control unit on the center spoke trim with two 4 x 14 mm TORX screws.

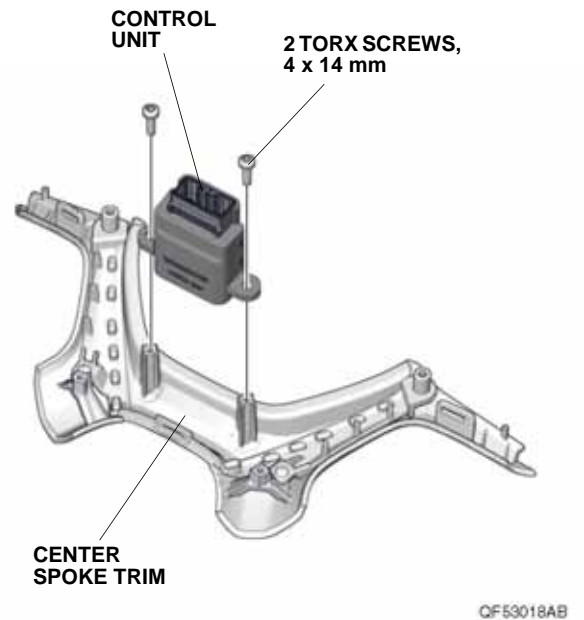

33. Plug the new cable reel cord 14-pin connector into the control unit, and install the center spoke trim to the new steering wheel with two self-tapping screws removed in step 25.

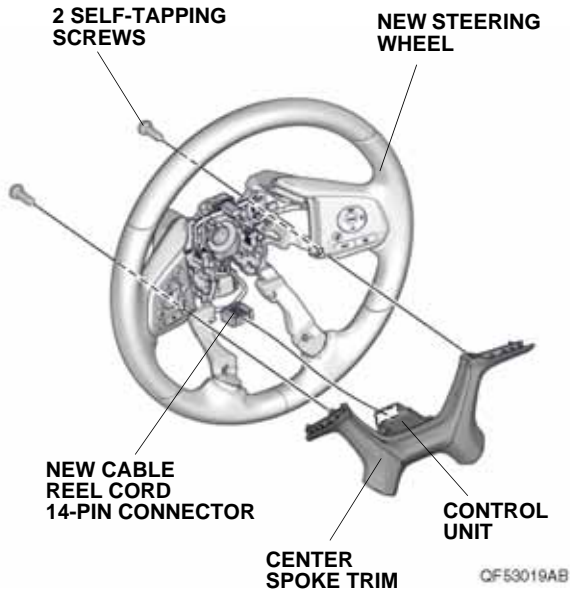

34. Install the left and right paddle shifters with four self-tapping screws removed in step 24. Plug two new cable reel cord 4-pin connectors into the two paddle shifter 4-pin connectors, and secure the two 4-pin connectors into the cable guide.

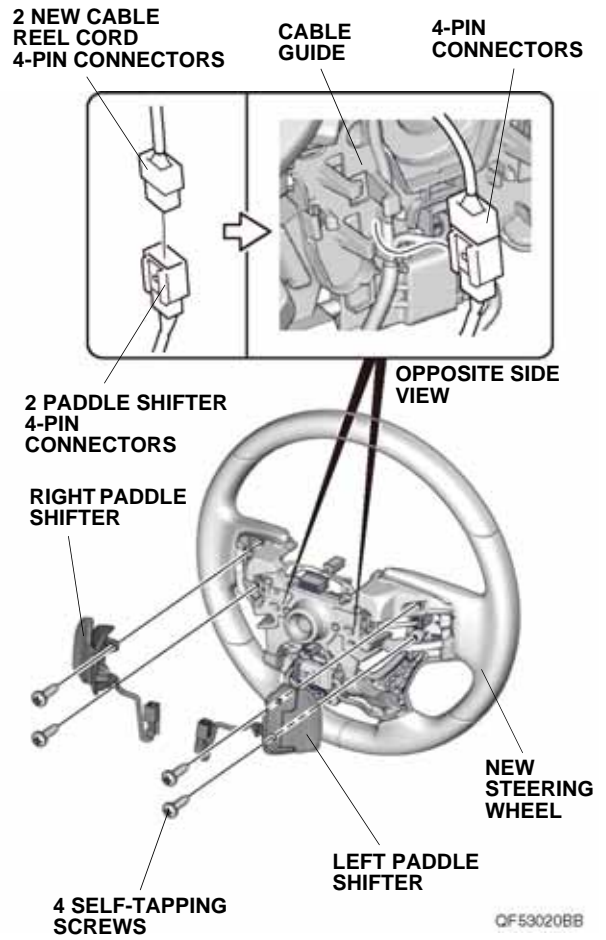

35. Install the steering wheel cover on the new steering wheel with the four self-tapping screws removed in step 23 and two retaining tabs.

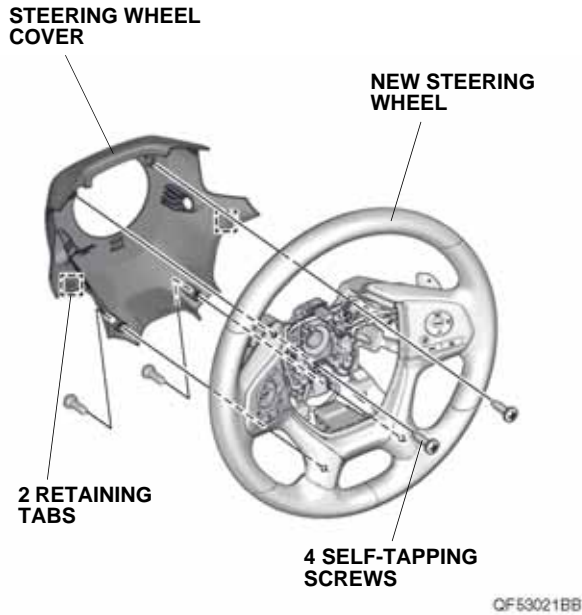

36. Install the lower column cover and upper column cover.

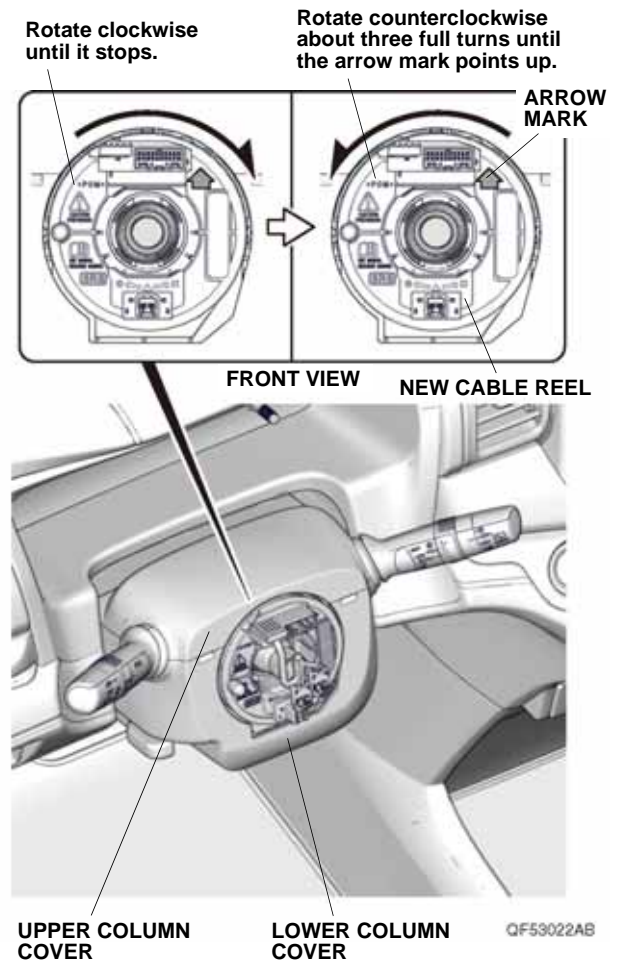

37. Before installing the new steering wheel, make sure the front wheels are pointing straight ahead, then center the new cable reel. Do this by first rotating the new cable reel clockwise until it stops, then rotate it counterclockwise about three full turns. The arrow mark on the new cable reel label should point straight up.

38. Install the new steering wheel on the steering column shaft in the straight-ahead position:
- Route the new cable reel 2-pin connectors cord through the opening in the new steering wheel. Route the new cable reel 2-pin connectors cord under the new cable reel cord, and secure it to the cable guide.
  - Plug the new cable reel cord 20-pin and 2-pin connectors into the new cable reel.
  - Check that the wire harnesses are not pinched.

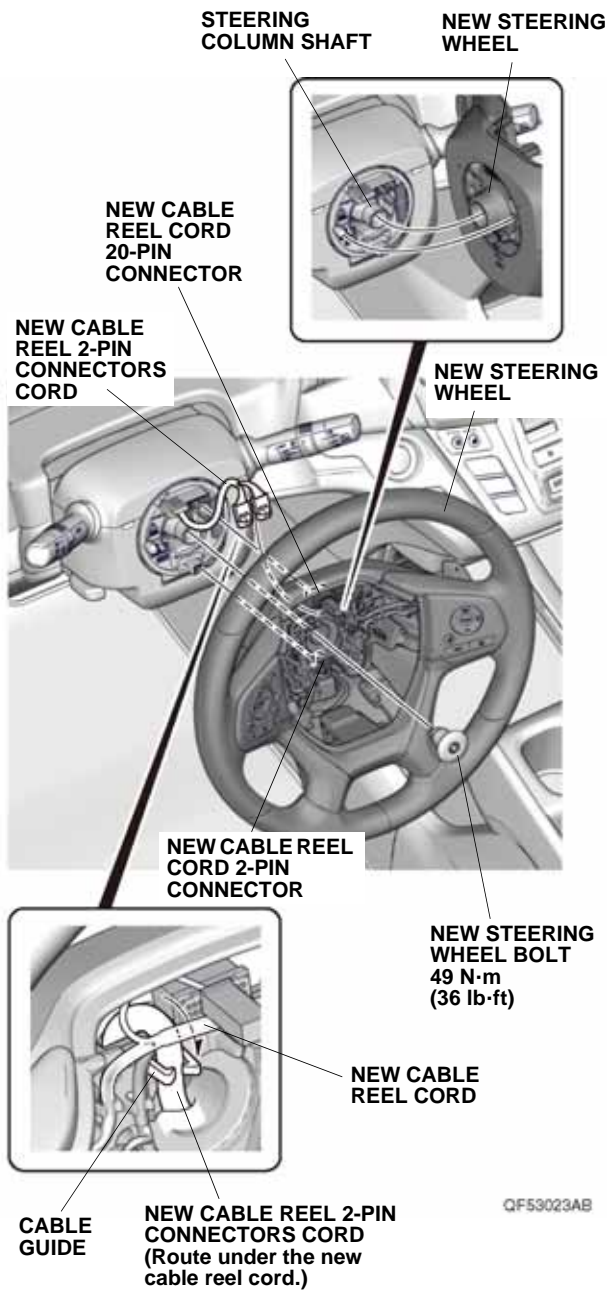

39. Install the new steering wheel bolt. Torque the new steering wheel bolt to 49 N·m (36 lb·ft). Tighten at the specified torque within 5 minutes.

40. Install the airbag to the new steering wheel with two supplied 6 x 23 mm TORX bolts and plug in the two new cable reel 2-pin connectors and one new cable reel cord 1-pin connector.
- Alternately tighten the right and left TORX bolts so that the gaps on the right and left sides between the airbag and the switches are even. Torque the new TORX bolts to 6.9-11.8 N·m (5.1-9 lb·ft).
  - New TORX bolts are coated with non-hardening thread lock sealant, so they cannot be reused. When installing the new steering wheel, be sure to replace the new TORX bolts with the ones included in this kit.

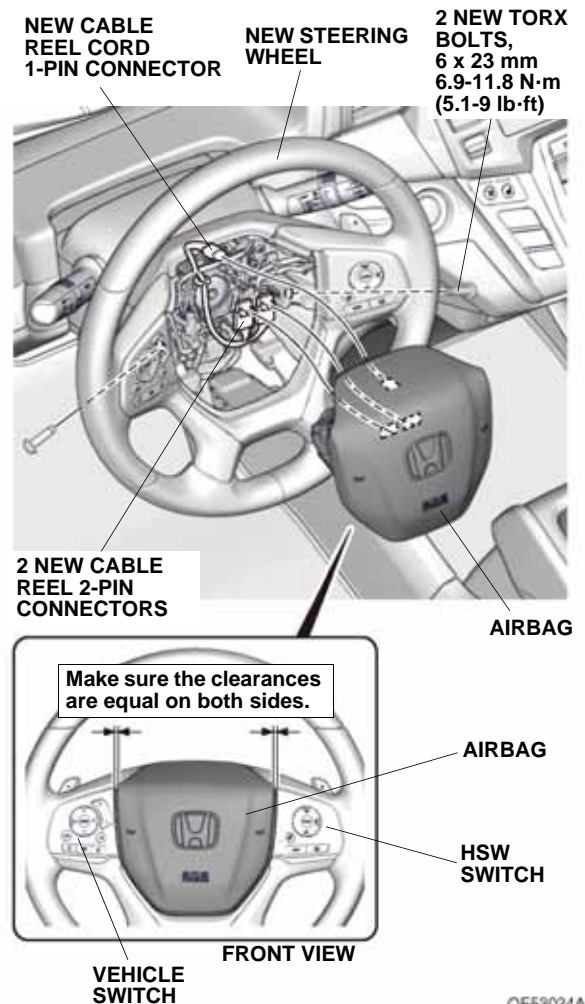

41. At the driver's dashboard lower cover opening, plug the 10A fuse into the fuse box in the slot shown.  
NOTE: If the 10A fuse is already installed, do not install the fuse.

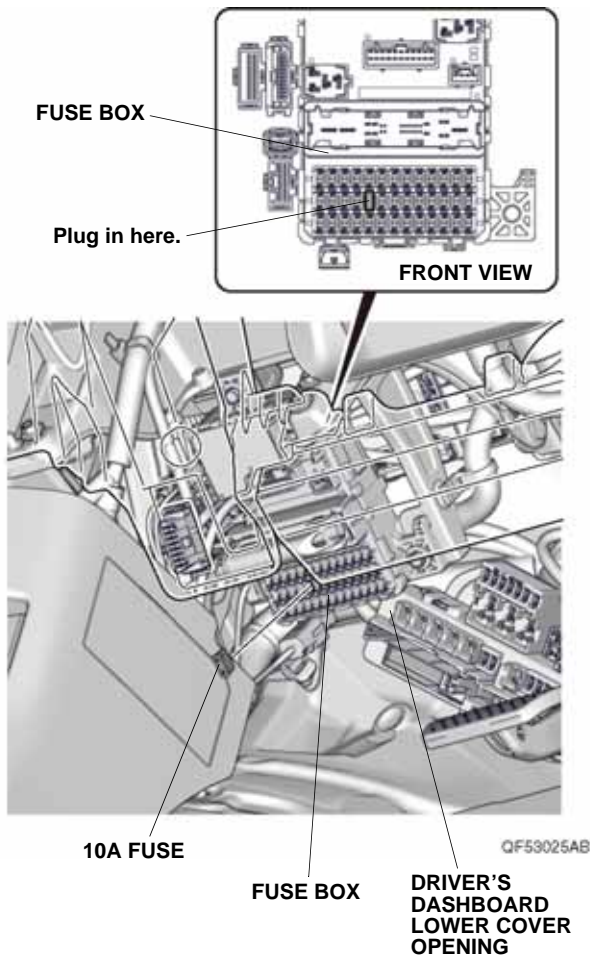

42. Check that all wire harnesses are routed properly and all connectors are plugged in.
43. Install all removed parts except for the front bulkhead cover and the intake air tube.
44. Connect the negative cable to the battery.
45. Install the front bulkhead cover and the intake air tube.
46. Connect the i-HDS/DST-i, and clear the DTCs.
47. Inspect the following items. If any abnormality is found, perform troubleshooting as described in the service information of the vehicle.
- Press the ENGINE START/STOP BUTTON to the ON mode: the SRS indicator should come on for about 6 seconds and then go off.
  - Make sure the horn and steering wheel switches work properly.
48. Press and hold the audio unit power button for 2 seconds to restore the audio and navi (if equipped) system functions.
49. Set the clock on vehicles without navigation.
50. If necessary, restore the systems back to normal operation as described in the service information.
51. Make sure the steering wheel is in the straight-ahead position with the front wheels. If the spoke angle of the steering wheel is not in the straight-ahead position with the front wheels, adjust the front toe as described in the service information.
52. Do the VSA sensor neutral position memorization as described in the service information.